



Quality Through Experience

DATA & COAXIAL CABLES

for SHIPBUILDING



Copyright © Notice and Disclaimer:

All data in this catalogue are only informative.
ÜNTEL KABLOLARI SAN. TIC. AS. reserve the right to modify the data at any time shown in this catalogue without notice. No part of this catalogue may be reproduced, distributed, or transmitted in any form or by any means, including photocopying, recording, or other electronic or mechanical methods, without the prior written permission of the Üntel Kablo. The names, trademarks and designs of our products are all protected by law. It does not constitute a warrantee of any kind, expressed or implied, of our products or their suitability for any particular use. There is no responsibility of the manufacturer for damages to persons and property in case of improper use, operation and installation of cables in this catalogue or/and neglecting the recommendations, standards and norms written in this catalogue.

Rev No. DMC-05-2025-R2

DATA CABLES FOR SHIPS



Quality Through Experience

ALMOST 50 YEARS IN PRODUCTION

ALMOST 50 YEARS IN PRODUCTION

Exporting Over 70 Countries on 6 Continents

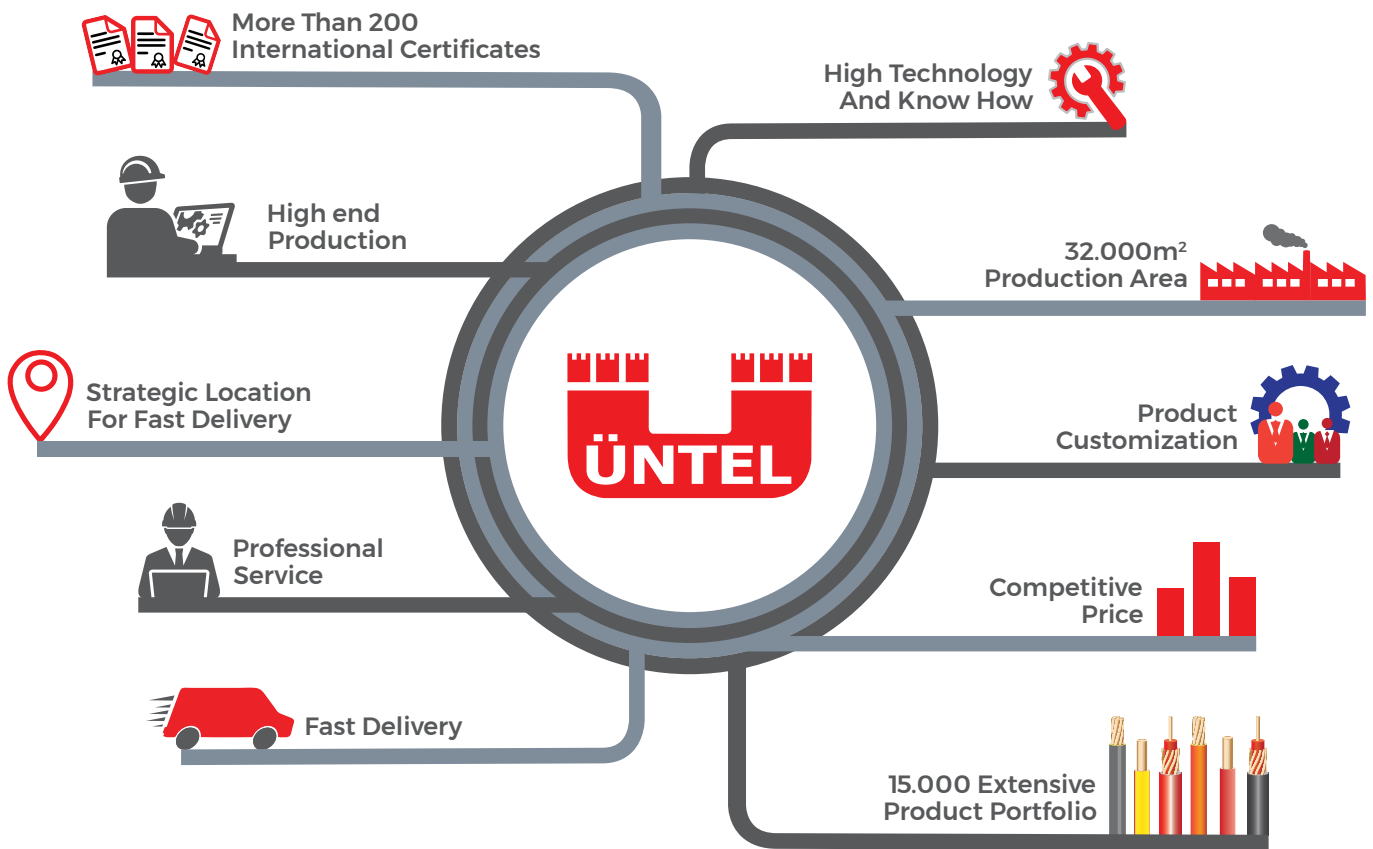

Industrial Cables



Marine Cables



Mining Cables



Offshore Cables



Railway Cables



Airport Runway Cables



Defense Cables



Crane Cables



ABOUT US

ÜNTEL KABLO, one of leading cable manufacturers in the world was established in 1972, Turkey. With almost 50 years of experience, continuously develops and optimize her product range with the help of advanced technology and well trained staff.

Product range consists over 15.000 different types of cables, covers both rubber and thermoplastic cables up to Medium Voltage (MV) range. ÜNTEL's power and instrumentation cables supplies energy for industries which requires experience like marine, offshore, mines and tunnels, airports, railways and have been used in industrial ways such as heavy-duty rubber drum reeling cables, welding cables, control cables and fire resistant cables. ÜNTEL is also able to produce tailor made products for special purposes. Today these products are exported over 70 countries on six continents.

By the end of 2009, ÜNTEL finalized the investment of a new high-tech plant near Istanbul. Now continues her operations on 43.000 m² land space with 32.000 m² closed area. By having 3.000 tons copper drawing and 4.000 tons different type of

compound processing capacity, ÜNTEL produces 30.000 tones of cable per year. By means of new factory building, state of the art machines and unique ERP system investments ÜNTEL aimed absolute customer satisfaction.

Üntel's laboratories which are approved by organisations that specify the standars are equipped with advanced technology test and measurement devices. Within the scope of Quality System Certificates there is a quality management system presents in Üntel according to ISO, IQnet and TSE quality standarts.. Around 200 different types of cables are certified by global organisations like VDE, KEMA, ABS, UL, BV, DNV-GL, RINA and TSE.

Üntel Kablo evaluate customer needs and expectations in a sectoral wiew and provide effective solutions with hundred percent customer satisfaction and qualified production philisopy. Üntel's biggest value is well trained and experienced staff and believe that exceptional quality comes through this experience.

Üntel Kablo offers type approved variety of
Marine cables, Navy cables and Offshore cables



You can find also in our portfolio power, control, telecommunication and signal
shipbuilding cables in accordance with IEC standards.

www.untel.com.tr



DATA CABLES FOR SHIPS

Longest journeys start with **“trust”**.

Üntel Kablo is one of the leading manufacturer of marine and shipbuilding cables in Europe and has been producing with approved quality more than **45+ years**

In this catalogue Üntel Kablo presents its series of shipboard energy, control, signal and instrumentation cables for fixed installations on vessels and other marine applications.

Shipbuilding involves the construction, reparation and renewing of ships or all kind of floating vessels like Cruise ships, LNG Tankers, Container ships, FPSOs, offshore support vessels and cargo or passenger vessel. Mainly shipbuilding industry is located at coastal areas called shipyards.

From cargo ships to cruise vessels, the technology used in shipbuilding requires high performance, more reliability and more safety through a complete range of shipboard cables including power, control, instrumentation, data transmission and communication cables with the best quality. Thus, the cables used in electrical installations must be easy to install (peel and bend), light and small, waterproof, fire resistant and low smoke and halogen free.

Üntel marine cables have been approved by its customers for an easy installation, enhanced flexibility, easy pulling, easy strippable and reduced size and weight.

Üntel Kablo produces Shipbuilding Cables in accordance with IEC 60092-350, IEC 60092-353, IEC 60092-354, and IEC 60092-376 features and design principles that developed throughout years of experience.

These cables are ideally suited for permanent installation on ships and boats, especially on desks and in cabins.

Our cables are produced with best quality compounds together with our decades of production experience to create solutions and added value for shipbuilders, owners and shipyards.

Üntel LSZH Shipbuilding cables meet the high requirements of safety on board and have been developed with improved characteristics to reduce the amount of toxic and corrosive gas emitted during combustion and hence do not cause secondary damage to the control, communication and power systems nor is it a threat to human life.

Our Shipbuilding and Marine Cables have been type approved by very reputable classification institutions like TL, ABS, DNV-GL, LR, RINA, RMRS, NKK and BV

While continuously investing on Research & Development and being in the market with more than 45 years of experience, producing wide variety of cables with high-tech production machines and with well trained staff enables Üntel to satisfy customers special requests and needs by supplying the best quality products.

Please go through our product pages for further technical information, if your requirement is for more specialised or for technical support or assistance, our technical team is at your disposal.

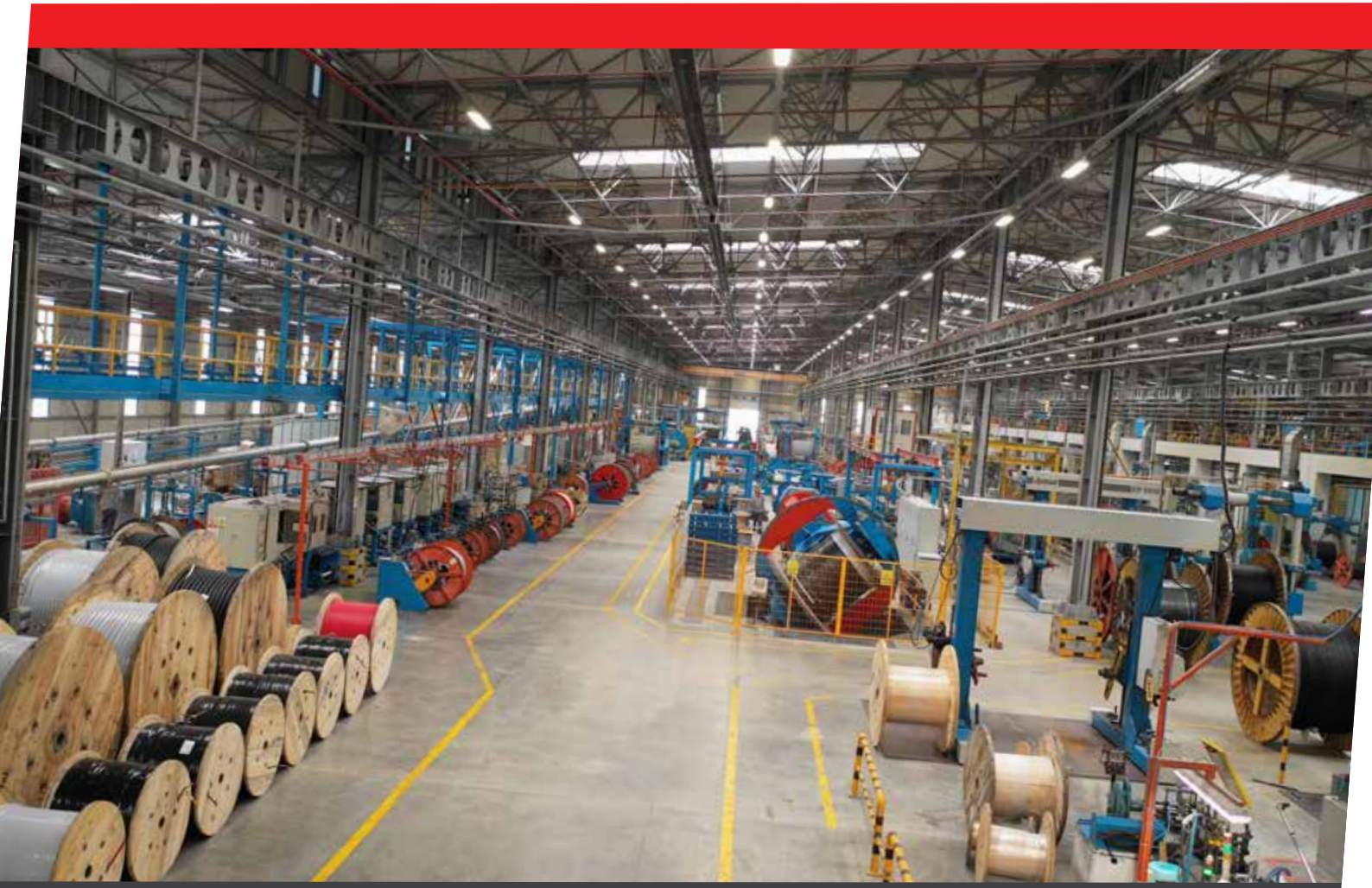

INDEX

PAGE

• EC600 SSTP FLEX HFFR CAT7 S/FTP	10
• EC900 SSTP HFFR CAT 7 S/FTP.....	12
• EC200 SFTP HFFR CAT5e SF/UTP	14
• RG 58 C/U (CuSn/CuSn)	16
• RG 58 C/U (CuSn/CuSn) (Double Shielded)	17
• RG 59 U/4 (Cu/Al) (Double Shielded)	18
• RG 59 B/U (Cu/Cu) (Double Shielded)	19
• RG 6 U/4 (Cu/Al) (Double Shielded)	20
• RG 6 A/U (Cu/CuAg) (Double Shielded)	21
• RG 11 A/U (CuSn/Cu) (Double Shielded)	22
• RG 213 /U (Cu/Cu)	23
• RG 213 /U (Cu/Cu) (Double Shielded)	24
• RG 214 /U (CuAg/CuAg) (Double Shielded)	25
• RG 214 /U (CuAg/CuAg) (Triple Shielded)	26
• TECHNICAL DATA	30



CABLE STRUCTURE

Conductor	7 x 0,22 mm Twisted Bare Copper
Insulation	Skin/Foam/Skin PE compound
Pair Screen	Al-Pet Foil around each pair
Overall Screen	Tinned Copper Wire Braiding
Sheath	Halogen free flame retardant compound (SHF1)

TECHNICAL PROPERTIES

Overall diameter	Ø 8,70 ± 0,20 mm
Cable Weight	90 kg / km
Min. Bending radius during draw in	70 mm
Min. Bending radius permanently installed	35 mm
Max. Tensile Strength	90 N
Min. Crush Resistance	1000 N / 10 cm
Installation Temperature	0°C / +50°C
Operating Temperature	-20°C / +70°C
Standarts	IEC 61156-5, EN 50288-4-1, EN 50173-1, ISO/IEC 11801 2nd ed IEC 60332-1-2, IEC 60332-3-24
Flame Retardant	
Halogen Free	IEC 60684-2, IEC60754-1/2
Low Smoke	IEC 61034-1/2
UV Resistant	ISO 4892-2

ELECTRICAL PROPERTIES at 20°C

Max. Conductor Resistance	< 9.5 Ω / km
Max. Resistance Unbalance	< 2 %
Min. Insulation Resistance	5000 MΩ x m
Mutual Capacitance	< 56 pF / m
Capacitance Unbalance	1600 pF / km
Impedance at 100 MHz	100 ± 5 Ω
Velocity of Propagation	76%
Delay Skew	< 25 ns / 100 m
Coupling Attenuation	> 85 Db
Transfer Impedance at 1 / 10 / 30 MHz	< 10 / 10 / 30 mΩ / m
Segregation Class	D
Test Voltage	1000V
Operating Voltage	125V

APPLICATIONS

IEEE 802.3: 10Base-T, 100Base-T, 1000Base-T, 10GBase-T, IEEE 802.5 16 MB, ISDN, TPDDI, ATM Power over Ethernet (PoE) / PoE+. These cables are used in data communication networks and for the transmission of digital and analogue voice, video and signals on ships.



Nominal Transmission Characteristics at 20 °C

Frequency (MHz)	Attenuation (dB/100 m)	NEXT (dB)	PS - NEXT (dB)	ACR (dB/100 m)	PS-ACR (dB/100 m)	ACRF (dB/100 m)	PS-ACRF (dB/100m)	Return Loss (dB)
1	2.0	104	101	99	96	101	98	24
4	3.4	104	101	97	94	98	95	30
10	4.9	101	98	95	92	98	95	32
100	17.3	100	97	82	79	84	81	34
250	28.2	95	92	63	60	70	67	27
500	42.0	95	92	56	53	61	58	24
600	44.0	88	85	45	42	59	56	22
700	53.5	84	81	30	27	52	49	20
800	55.5	83	80	28	25	50	47	19
900	57.3	80	77	23	20	49	46	18
1000	59.1	77	75	23	20	48	45	18



CABLE STRUCTURE

Conductor	23 AWG Bare Copper
Insulation	Skin/Foam/Skin PE compound
Pair Screen	Al-Pet Foil around each pair
Overall Screen	Tinned Copper Wire Braiding
Sheath	Halogen free flame retardant compound (SHF1)

TECHNICAL PROPERTIES

Overall diameter	Ø 7,30 ± 0,20 mm
Cable Weight	58 kg/km
Min. Bending radius during draw in	60 mm
Min. Bending radius permanently installed	30 mm
Max. Tensile Strength	90 N
Min. Crush Resistance	1000 N/10 cm
Min. Impact	10 Impacts
Installation Temperature	0°C / +50°C
Operating Temperature	- 20°C / +70°C
Standarts	IEC 61156-5, EN 50288-4-1, EN 50173-1, ISO/IEC 11801 2nd ed
Flame Retardant	IEC 60332-1-2, IEC 60332-3-24
Halogen Free	IEC 60684-2, IEC 60754-1/2
Low Smoke	IEC 61034-1/2
UV Resistant	ISO 4892-2

ELECTRICAL PROPERTIES at 20°C

Max. Conductor Resistance	< 9.5 Ω / km
Max. Resistance Unbalance	< 2 %
Min. Insulation Resistance	5000 MΩ x m
Mutual Capacitance	< 56 pF / m
Capacitance Unbalance	1600 pF / km
Impedance at 100 MHz	100 ± 5 Ω
Velocity of Propagation	76%
Delay Skew	< 25 ns / 100 m
Coupling Attenuation	80 Db
Transfer Impedance at 1 / 10 / 30 MHz	< 10 / 10 / 30 mΩ / m
Segregation Class	D
Test Voltage	1000 V
Operating Voltage	125 V

APPLICATIONS

IEEE 802.3: 10Base-T, 100Base-T, 1000Base-T, 10GBase-T, IEEE 802.5 16 MB, ISDN, TPDDI, ATM Power over Ethernet (PoE) / PoE+. These cables are used in data communication networks and for the transmission of digital and analogue voice, video and signals on ships.



FLAME RETARDANT



HALOGEN-FREE



LOW SMOKE



NO CORROSION

Nominal Transmission Characteristics at 20 °C

Frequency (MHz)	Attenuation (dB/100 m)	NEXT (dB)	PS - NEXT (dB)	ACR (dB/100 m)	PS-ACR (dB/100 m)	ACRF (dB/100 m)	PS-ACRF (dB/100m)	Return Loss (dB)
1	2.0	104	101	99	96	101	98	24
4	3.4	104	101	97	94	98	95	30
10	4.9	101	98	95	92	98	95	32
100	17.3	100	97	82	79	84	81	34
250	28.2	95	92	63	60	70	67	27
500	42.0	95	92	56	53	61	58	24
600	44.0	88	85	45	42	59	56	22
700	53.5	84	81	30	27	52	49	20
800	55.5	83	80	28	25	50	47	19
900	57.3	80	77	23	20	49	46	18
1000	59.1	77	75	23	20	48	45	18



CABLE STRUCTURE

Conductor	24 AWG Bare Copper
Insulation	PE compound
Overall Screen	Al-Pet Foil and Tinned Copper Wire Braiding
Sheath	Halogen free flame retardant compound (SHFI)

TECHNICAL PROPERTIES

Overall diameter	Ø 6,20 ± 0,20 mm
Cable Weight	48 kg/km
Min. Bending radius during draw in	50 mm
Min. Bending radius permanently installed	25 mm
Max. Tensile Strength	90 N
Min. Crush Resistance	1000 N/10 cm
Min. Impact	10 Impacts
Installation Temperature	0°C / +50°C
Operating Temperature	- 20°C / +70°C
Standarts	IEC 61156-5, EN 50288-2-1, EN 50173-1, ISO/IEC 11801 2nd ed
Flame Retardant	IEC 60332-1-2, IEC 60332-3-24
Halogen Free	IEC 60684-2, IEC60754-1/2
Low Smoke	IEC 61034-1/2

ELECTRICAL PROPERTIES at 20°C

Max. Conductor Resistance	< 9.5 Ω / km
Max. Resistance Unbalance	< 2 %
Min. Insulation Resistance	5000 MΩ x m
Mutual Capacitance	< 60 pF / m
Capacitance Unbalance	1600 pF / km
Impedance at 100 MHz	100 ± 5 Ω
Velocity of Propagation	66 %
Delay Skew	< 45 ns / 100 m
Test Voltage	1000 V
Operating Voltage	125 V

APPLICATIONS

IEEE 802.3: 10Base-T, 100Base-T, 1000Base-T, IEEE 802.5 16 MB, ISDN, TPDDI, ATM Power over Ethernet (PoE) / PoE+. These cables are used in data communication networks with 200 MHz bandwidth capacity. And for the transmission of digital and analogue voice, video and signals on ships.



FLAME RETARDANT



HALOGEN - FREE



LOW SMOKE



NO COROSIVITY

Nominal Transmission Characteristics at 20 °C

Frequency (MHz)	Attenuation (dB/100 m)	NEXT (dB)	PS - NEXT (dB)	ACR (dB/100 m)	PS-ACR (dB/100 m)	ACRF (dB/100 m)	PS-ACRF (dB/100m)	Return Loss (dB)
1	2.0	70	67	68	65	78	75	21
4	3.6	62	59	58	55	70	67	29
10	5.7	55	52	50	47	52	49	30
16	7.7	55	52	45	42	50	47	30
31.2	11.2	48	45	40	37	35	32	29
62.5	16.4	48	45	30	27	35	32	27
100	20.9	40	37	20	17	30	27	27
200	27.3	35	32	10	7	20	17	20



CABLE STRUCTURE

Inner Conductor	19 x 0,18 mm stranded tinned copper wire
Insulation	Solid Polyethylene compound
Screen	Tinned copper wire braiding
Outer Sheath	Halogen free flame retardant compound (SHFI)

TECHNICAL PROPERTIES

Overall diameter:	Ø 4,95 ± 0,20 mm
Cable Weight	45 kg/km
Min. Bending Radius	45 mm
Max. Tensile Strength	30 N
Operating Temperature	-20 °C / +70 °C
Construction	EN 50117-1 (MIL-C-17)
Flame Retardant	EN 60332-1-2, IEC 60332-3-24
Halogen Content	IEC 60754-1/2, IEC 60684-2
Smoke Emission	IEC 61034-1/2

ELECTRICAL PROPERTIES at 20°C

Max. Conductor Resistance	38,5 Ω / km
Min. Insulation Resistance	1 GΩ x km
Capacitance	98 ± 4 pF / m
Impedance	50 ± 2 Ω
Velocity of Propagation	66%
Test Voltage	5 kV
Operating Voltage	1000 V

Attenuations at 20°C

10 MHz	4.70 dB / 100m
100 MHz	15.70 dB / 100m
200 MHz	23.00 dB / 100m
400 MHz	34.50 dB / 100m
1000 MHz	60.00 dB / 100m

APPLICATIONS

These types of cables are used for antenna connections of CB, cordless systems and connection cables for terminals and systems of data transmission networks. Halogen Free, Non Corrosive and Flame retardant, thanks to the HFFR Compound that has been used on their construction.



FLAME RETARDANT



HALOGEN-FREE



LOW SMOKE



NO CORROSION

MARINE COAX CABLE
(Double Shielded)

RoHS



CABLE STRUCTURE

Inner Conductor	19 x 0,18 mm stranded tinned copper wire
Insulation	Solid Polyethylene compound
Screen 1	Aluminium/poleysther/aluminium tape
Screen 2	Tinned copper wire braiding
Outer Sheath	Halogen free flame retardant compound (SHFI)

TECHNICAL PROPERTIES

Overall diameter:	Ø 5,00 ± 0,20 mm
Cable Weight	46 kg/km
Min. Bending Radius	45 mm
Max. Tensile Strength	30 N
Operating Temperature	-20 °C / +70 °C
Construction	EN 50117-1 (MIL-C-17)
Flame Retardant	EN 60332-1-2, IEC 60332-3-24
Halogen Content	IEC 60754-1/2, IEC 60684-2
Smoke Emission	IEC 61034-1/2

ELECTRICAL PROPERTIES at 20°C

Max. Conductor Resistance	38,5 Ω / km
Min. Insulation Resistance	1 GΩ x km
Capacitance	98 ± 4 pF / m
Impedance	50 ± 2 Ω
Velocity of Propagation	66%
Test Voltage	5 kV
Operating Voltage	1000 V

Attenuations at 20°C

10 MHz	4.50 dB / 100m
100 MHz	15.50 dB / 100m
200 MHz	23.80 dB / 100m
400 MHz	34.30 dB / 100m
1000 MHz	59.82 dB / 100m

APPLICATIONS

These types of cables are used for antenna connections of CB, cordless systems and connection cables for terminals and systems of data transmission networks. Halogen Free, Non Corrosive and Flame retardant, thanks to the HFFR Compound that has been used on their construction.



MARINE COAX CABLE
(Double Shielded)

RoHS



CABLE STRUCTURE

Inner Conductor	0,80 mm bare solid copper
Insulation	Gas Injected Skin/Foam/Skin Polyethylene compound
Screen 1	Aluminum foil (bonded to the Insulation)
Screen 2	Aluminum wire braiding
Outer Sheath :	Halogen free flame retardant compound (SHFI)

TECHNICAL PROPERTIES

Overall diameter:	Ø 5,80 ± 0,20 mm
Cable Weight	35 kg/km
Min. Bending Radius	50 mm
Max. Tensile Strength	30 N
Operating Temperature	-20 °C / +70 °C
Screening Class	Class C
Construction	EN 50117-2-4 (MIL-C-17)
Flame Retardant	EN 60332-1-2, IEC 60332-3-24
Halogen Content	IEC 60754-1/2, IEC 60684-2
Smoke Emission	IEC 61034-1/2

ELECTRICAL PROPERTIES at 20°C

Max. Conductor Resistance	34,5 Ω / km
Min. Insulation Resistance	2 GΩ x km
Capacitance	53 ± 3 pF / m
Impedance	75 ± 2 Ω
Transfer Impedance at 5-30 Mhz	≤ 50 mΩ/m
Velocity of Propagation	83 ± 3 %
Test Voltage	5 kV
Operating Voltage	1000 V

Attenuations at 20°C

5 MHz	2.20 dB / 100m
50 MHz	5.80 dB / 100m
230 MHz	11.90 dB / 100m
470 MHz	17.70 dB / 100m
860 MHz	23.90 dB / 100m
1000 MHz	25.75 dB / 100m
1200 MHz	33.20 dB / 100m
2150 MHz	38.50 dB / 100m
3000 MHz	48.75 dB / 100m

Return Loss at 20°C

5-470 MHz	> 26 dB
470-1200 MHz	> 23 dB
1200-2000 MHz	> 20 dB
2000-3000 MHz	> 18 dB

Screen Attenuations

30-1200 MHz	≥ 75 dB
1200-2000 MHz	≥ 65 dB
2000-3000 MHz	≥ 55 dB

APPLICATIONS

These types of cables are used for CCTV and indoor CATV distributions and connections of systems which require low attenuations. These cables are Halogen Free, Non Corrosive and Flame retardant, thanks to the HFFR Compound that has been used on their construction.



MARINE COAX CABLE
(Double Shielded)

RoHS



CABLE STRUCTURE

Inner Conductor	0,58 mm bare solid copper
Insulation	Solid Polyethylene compound
Screen 1	Aluminium/poleysther/aluminium tape
Screen 2	Copper wire braiding
Outer Sheath :	Halogen free flame retardant compound (SHF1)

TECHNICAL PROPERTIES

Overall diameter:	Ø 6,20 ± 0,20 mm
Cable Weight	65 kg/km
Min. Bending Radius	50 mm
Max. Tensile Strength	30 N
Operating Temperature	-20 °C / +70 °C
Screening Class	Class C
Construction	EN 50117 (MIL-C-17)
Flame Retardant	EN 60332-1-2, IEC 60332-3-24
Halogen Content	IEC 60754-1/2, IEC 60684-2
Smoke Emission	IEC 61034-1/2

ELECTRICAL PROPERTIES at 20°C

Max. Conductor Resistance	65,3 Ω / km
Min. Insulation Resistance	2 GΩ x km
Capacitance	67 ± 4 pF / m
Impedance	75 ± 3 Ω
Transfer Impedance at 5-30 Mhz	≤ 50 mΩ/m
Velocity of Propagation	66%
Test Voltage	5 kV
Operating Voltage	1000 V

Attenuations at 20°C

10 MHz	3.50 dB / 100m
50 MHz	7.40 dB / 100m
100 MHz	10.30 dB / 100m
200 MHz	14.80 dB / 100m
300 MHz	17.90 dB / 100m
500 MHz	23.80 dB / 100m
1000 MHz	34.60 dB / 100m
2500 MHz	58.90 dB / 100m

APPLICATIONS

These types of cables are used for antenna connections of CB, cordless systems and connection cables for terminals and systems of data transmission networks. These cables are Halogen Free, Non Corrosive and Flame retardant, thanks to the HFFR Compound that has been used on their construction.



MARINE COAX CABLE
(Double Shielded)

RoHS



CABLE STRUCTURE

Inner Conductor	1,02 mm bare solid copper
Insulation	Gas Injected Skin/Foam/Skin Polyethylene compound
Screen 1	Aluminium/poleysther/aluminium tape
Screen 2	Aluminum wire braiding
Outer Sheath :	Halogen free flame retardant compound (SHFI)

TECHNICAL PROPERTIES

Overall diameter:	Ø 6,70 ± 0,20 mm
Cable Weight	44 kg/km
Min. Bending Radius	55 mm
Max. Tensile Strength	30 N
Operating Temperature	-20 °C / +70 °C
Screening Class	Class C
Construction	EN 50117-2-4 (MIL-C-17)
Flame Retardant	EN 60332-1-2, IEC 60332-3-24
Halogen Content	IEC 60754-1/2, IEC 60684-2
Smoke Emission	IEC 61034-1/2

ELECTRICAL PROPERTIES at 20°C

Max. Conductor Resistance	22,1 Ω / km
Min. Insulation Resistance	2 GΩ x km
Capacitance	53 ± 2 pF / m
Impedance	75 ± 3 Ω
Transfer Impedance at 5-30 Mhz	≤ 50 mΩ/m
Velocity of Propagation	84%
Test Voltage	5 kV
Operating Voltage	1000 V

Attenuations at 20°C

5 MHz	1.80 dB / 100m
50 MHz	5.60 dB / 100m
230 MHz	9.25 dB / 100m
470 MHz	14.10 dB / 100m
860 MHz	19.00 dB / 100m
1000 MHz	21.10 dB / 100m
1200 MHz	23.20 dB / 100m
2150 MHz	34.10 dB / 100m
3000 MHz	39.05 dB / 100m

Return Loss at 20°C

5-470 MHz	> 26 dB
470-1200 MHz	> 23 dB
1200-2000 MHz	> 20 dB
2000-3000 MHz	> 18 dB

Screen Attenuations

30-1200 MHz	≥ 75 dB
1200-2000 MHz	≥ 65 dB
2000-3000 MHz	≥ 55 dB

APPLICATIONS

These types of cables are used for antenna connections of CB, cordless systems and connection cables for terminals and systems of data transmission networks. These cables are Halogen Free, Non Corrosive and Flame retardant, thanks to the HFFR Compound that has been used on their construction.



MARINE COAX CABLE
(Double Shielded)

RoHS



CABLE STRUCTURE

Inner Conductor	0,75 mm bare solid copper
Insulation	Solid Polyethylene compound
Screen 1	Aluminium/poleysther/aluminium tape
Screen 2	Silver coated copper wire braiding
Outer Sheath :	Halogen free flame retardant compound (SHF1)

TECHNICAL PROPERTIES

Overall diameter:	Ø 8,40 ± 0,20 mm
Cable Weight	135 kg/km
Min. Bending Radius	70 mm
Max. Tensile Strength	30 N
Operating Temperature	-20 °C / +70 °C
Construction	EN 50117 (MIL-C-17)
Flame Retardant	EN 60332-1-2, IEC 60332-3-24
Halogen Content	IEC 60754-1/2, IEC 60684-2
Smoke Emission	IEC 61034-1/2

ELECTRICAL PROPERTIES at 20°C

Max. Conductor Resistance	40,2 Ω / km
Min. Insulation Resistance	2 GΩ x km
Capacitance	67 ± 3 pF / m
Impedance	75 ± 3 Ω
Velocity of Propagation	66%
Test Voltage	5 kV
Operating Voltage	1000 V

Attenuations at 20°C

10 MHz	2.40 dB / 100m
50 MHz	5.70 dB / 100m
100 MHz	8.10 dB / 100m
200 MHz	11.70 dB / 100m
300 MHz	14.50 dB / 100m
500 MHz	19.00 dB / 100m
1000 MHz	27.70 dB / 100m
2500 MHz	46.60 dB / 100m

APPLICATIONS

These types of cables are used for antenna connections of CB, cordless systems and connection cables for terminals and systems of data transmission networks. These cables are Halogen Free, Non Corrosive and Flame retardant, thanks to the HFFR Compound that has been used on their construction.



MARINE COAX CABLE
(Double Shielded)

RoHS



CABLE STRUCTURE

Inner Conductor	7x0.40 mm stranded tinned copper wire
Insulation	Solid Polyethylene compound
Screen 1	Aluminium/poleysther/aluminium tape
Screen 2	Copper wire braiding
Outer Sheath :	Halogen free flame retardant compound (SHFI)

TECHNICAL PROPERTIES

Overall diameter:	Ø 10,30 ± 0,20 mm
Cable Weight	160 kg/km
Min. Bending Radius	85 mm
Max. Tensile Strength	30 N
Operating Temperature	-20 °C / +70 °C
Construction	EN 50117 (MIL-C-17)
Flame Retardant	EN 60332-1-2, IEC 60332-3-24
Halogen Content	IEC 60754-1/2, IEC 60684-2
Smoke Emission	IEC 61034-1/2

ELECTRICAL PROPERTIES at 20°C

Max. Conductor Resistance	20,5 Ω / km
Min. Insulation Resistance	2 GΩ x km
Capacitance	67 ± 3 pF / m
Impedance	75 ± 3 Ω
Velocity of Propagation	66%
Test Voltage	5 kV
Operating Voltage	1000 V

Attenuations at 20°C

10 MHz	1.50 dB / 100m
50 MHz	4.20 dB / 100m
100 MHz	6.10 dB / 100m
200 MHz	9.20 dB / 100m
300 MHz	11.80 dB / 100m
500 MHz	16.00 dB / 100m
1000 MHz	24.30 dB / 100m
2500 MHz	42.50 dB / 100m

APPLICATIONS

These types of cables are used for antenna connections of CB, cordless systems and connection cables for terminals and systems of data transmission networks. These cables are Halogen Free, Non Corrosive and Flame retardant, thanks to the HFFR Compound that has been used on their construction.



FLAME RETARDANT



HALOGEN-FREE



LOW SMOKE



NO CORROSIIVITY



CABLE STRUCTURE

Inner Conductor	7x0.75 mm stranded bare copper wire
Insulation	Solid Polyethylene compound
Screen	Copper wire braiding
Outer Sheath :	Halogen free flame retardant compound (SHFI)

TECHNICAL PROPERTIES

Overall diameter:	Ø 10,30 ± 0,20 mm
Cable Weight	185 kg/km
Min. Bending Radius	85 mm
Max. Tensile Strength	30 N
Operating Temperature	-20 °C / +70 °C
Construction	EN 50117 (MIL-C-17)
Flame Retardant	EN 60332-1-2, IEC 60332-3-24
Halogen Content	IEC 60754-1/2, IEC 60684-2
Smoke Emission	IEC 61034-1/2

ELECTRICAL PROPERTIES at 20°C

Max. Conductor Resistance	6,0 Ω / km
Min. Insulation Resistance	2 GΩ x km
Capacitance	100 ± 3 pF / m
Impedance	50 ± 2 Ω
Velocity of Propagation	66%
Test Voltage	5 kV
Operating Voltage	1000 V

Attenuations at 20°C

50 MHz	4.50 dB / 100m
100 MHz	6.70 dB / 100m
200 MHz	9.90 dB / 100m
400 MHz	14.30 dB / 100m
500 MHz	16.10 dB / 100m
1000 MHz	24.30 dB / 100m

APPLICATIONS

These types of cables are used for antenna connections of CB, cordless systems and connection cables for terminals and systems of data transmission networks. These cables are Halogen Free, Non Corrosive and Flame retardant, thanks to the HFFR Compound that has been used on their construction.



MARINE COAX CABLE
(Double Shielded)

RoHS



CABLE STRUCTURE

Inner Conductor	7x0.75 mm stranded bare copper wire
Insulation	Solid Polyethylene compound
Screen 1	Aluminium/poleysther/aluminium tape
Screen 2	Copper wire braiding
Outer Sheath :	Halogen free flame retardant compound (SHF1)

TECHNICAL PROPERTIES

Overall diameter:	Ø 10,40 ± 0,20 mm
Cable Weight	186 kg/km
Min. Bending Radius	85 mm
Max. Tensile Strength	30 N
Operating Temperature	-20 °C / +70 °C
Construction	EN 50117 (MIL-C-17)
Flame Retardant	EN 60332-1-2, IEC 60332-3-24
Halogen Content	IEC 60754-1/2, IEC 60684-2
Smoke Emission	IEC 61034-1/2

ELECTRICAL PROPERTIES at 20°C

Max. Conductor Resistance	6,0 Ω / km
Min. Insulation Resistance	2 GΩ x km
Capacitance	100 ± 3 pF / m
Impedance	50 ± 2 Ω
Velocity of Propagation	66%
Test Voltage	5 kV
Operating Voltage	1000 V

Attenuations at 20°C

50 MHz	4.50 dB / 100m
100 MHz	6.70 dB / 100m
200 MHz	9.90 dB / 100m
400 MHz	14.30 dB / 100m
500 MHz	16.10 dB / 100m
1000 MHz	24.30 dB / 100m

APPLICATIONS

These types of cables are used for antenna connections of CB, cordless systems and connection cables for terminals and systems of data transmission networks. These cables are Halogen Free, Non Corrosive and Flame retardant, thanks to the HFFR Compound that has been used on their construction.



MARINE COAX CABLE
(Double Shielded)

RoHS



CABLE STRUCTURE

Inner Conductor	7x0.75 mm stranded silver coated copper wire
Insulation	Solid Polyethylene compound
Screen 1	Silver coated copper wire braiding
Screen 2	Silver coated copper wire braiding
Outer Sheath :	Halogen free flame retardant compound (SHFI)

TECHNICAL PROPERTIES

Overall diameter:	Ø 10,80 ± 0,20 mm
Cable Weight	226 kg/km
Min. Bending Radius	90 mm
Max. Tensile Strength	30 N
Operating Temperature	-20 °C / +70 °C
Construction	EN 50117 (MIL-C-17)
Flame Retardant	EN 60332-1-2, IEC 60332-3-24
Halogen Content	IEC 60754-1/2, IEC 60684-2
Smoke Emission	IEC 61034-1/2

ELECTRICAL PROPERTIES at 20°C

Max. Conductor Resistance	6,0 Ω / km
Min. Insulation Resistance	2 GΩ x km
Capacitance	100 ± 3 pF / m
Impedance	50 ± 2 Ω
Velocity of Propagation	66%
Test Voltage	5 kV
Operating Voltage	1000 V

Attenuations at 20°C

10 MHz	2.00 dB / 100m
50 MHz	4.30 dB / 100m
100 MHz	6.00 dB / 100m
200 MHz	8.20 dB / 100m
300 MHz	10.10 dB / 100m
500 MHz	13.50 dB / 100m
1000 MHz	20.30 dB / 100m
2500 MHz	37.40 dB / 100m

APPLICATIONS

These types of cables are used for antenna connections of CB, cordless systems and connection cables for terminals and systems of data transmission networks. These cables are Halogen Free, Non Corrosive and Flame retardant, thanks to the HFFR Compound that has been used on their construction.



MARINE COAX CABLE
(Triple Shielded)

RoHS



CABLE STRUCTURE

Inner Conductor	7x0.75 mm stranded silver coated copper wire
Insulation	Solid Polyethylene compound
Screen 1	Aluminium/poleyster/aluminium tape
Screen 2	Silver coated copper wire braiding
Screen 3	Silver coated copper wire braiding
Outer Sheath :	Halogen free flame retardant compound (SHF1)

TECHNICAL PROPERTIES

Overall diameter:	Ø 10,90 ± 0,20 mm
Cable Weight	228 kg/km
Min. Bending Radius	90 mm
Max. Tensile Strength	30 N
Operating Temperature	-20 °C / +70 °C
Construction	EN 50117 (MIL-C-17)
Flame Retardant	EN 60332-1-2, IEC 60332-3-24
Halogen Content	IEC 60754-1/2, IEC 60684-2
Smoke Emission	IEC 61034-1/2

ELECTRICAL PROPERTIES at 20°C

Max. Conductor Resistance	6,0 Ω / km
Min. Insulation Resistance	2 GΩ x km
Capacitance	100 ± 3 pF / m
Impedance	50 ± 2 Ω
Velocity of Propagation	66%
Test Voltage	5 kV
Operating Voltage	1000 V

Attenuations at 20°C

10 MHz	2.00 dB / 100m
50 MHz	4.30 dB / 100m
100 MHz	6.00 dB / 100m
200 MHz	8.20 dB / 100m
300 MHz	10.10 dB / 100m
500 MHz	13.50 dB / 100m
1000 MHz	20.30 dB / 100m
2500 MHz	37.40 dB / 100m

APPLICATIONS

These types of cables are used for antenna connections of CB, cordless systems and connection cables for terminals and systems of data transmission networks. These cables are Halogen Free, Non Corrosive and Flame retardant, thanks to the HFFR Compound that has been used on their construction.









TECHNICAL DATA

TECHNICAL DATA

MARINE CABLES STANDARDS

IEC 60092-350: Shipboard power cables - General construction and test requirements

IEC 60092-352: Electrical installation in ships - Choice and installation of electrical cables.

IEC 60092-353: Single and multicore non-radial field. Power cables with extruded solid insulation for rated voltages 1 kV and 3 kV

IEC 60092-354: Single and three-core power cables with extruded solid insulation for rated voltages 6 kV up to 30 kV.

IEC 60092-360: Insulating and sheathing materials for shipboard and offshore units, power, control, instrumentation and telecommunication cables.

IEC 60092-376: Cables for control and instrumentation circuits 150/250 V (300 V).

IEC 60228: Conductors of insulated cables.

IEC 60287: (all parts), Electric cables - Calculation of the current rating.

IEC 60331-21: Test for electric cables under fire conditions – Circuit integrity – Part 21 Procedures and requirements – Cables of rated voltage up to and including 0,6/1kV

IEC 60331-31: Tests for electric cables under fire conditions - Circuit integrity - Part 31: Procedures and requirements for fire with shock - Cables of rated voltage up to and including 0,6/1,0 kV

IEC 60331-1: Test method for fire with shock at a temperature of at least 830°C for cables of rated voltage up to and including 0,6/1 kV and with an overall diameter exceeding 20mm.

IEC 60331-2: Test method for fire with shock at a temperature of at least 830°C for cables of rated voltage up to and including 0,6/1 kV and with an overall diameter not exceeding 20mm.

IEC 60332-1-2: Test for vertical flame propagation for single insulated wire or cable.

IEC 60332-3-22: Test for vertical flame spread of vertically - mouted bunched wires or cables - Category A

IEC 60332-3-24: Test for vertical flame spread of vertically - mouted bunched wires or cables - Category C

IEC 60754-1: Test on gases evolved during combustion of materials from cables. Part 1: Determination of the halogen acid gas content.

IEC 60754-2: Test on gases evolved during combustion of materials from cables. Part 2: Determination of acidity (by pH measurement) and conductivity.

IEC 60811: Common test methods for insulating and sheathing materials of electric cables.

IEC 61034-1: Measurement of smoke density of cables burning under defined conditions - Part 1: Test apparatus.

IEC 61034-2: Measurement of smoke density of cables burning under defined conditions - Part 2: Test procedure and requirements.

IEC 60096-0-1: 2012 Radio frequency cables Part 0-1: Guide to the design of detail specifications - Coaxial cables

IEC 61156-5: Multicore and symmetrical pair/quad cables for digital communications - Part 5: Symmetrical pair/quad cables with transmission characteristics up to 1 000 MHz

MIL-DTL-17: US military specification for RG cables superseding MIL-C-17

MIL-C-17/28 - Cables, Radio Frequency, Flexible, Coaxial, 50 Ohms, M17/28-RG058, M17 / 183 - 00001

MIL-C-17/29 - Cables, Radio Frequency, Flexible, Coaxial, 75 Ohms, M17/29-RG059, M17 / 184 - 00001

MIL-C-17/2 - Cable, Radio Frequency, Flexible, Coaxial, 75 Ohms, M17/2-RG6, M17 / 180 - 00001

MIL-C-17/6 - Cables, Radio Frequency, Flexible, Coaxial, 75 Ohms, M17/6-RG11, M17 / 181 - 00002

MIL-C-17/74 - Cables, Radio Frequency, Flexible, Coaxial, 50 Ohms, M17/74-RG213 Unarmored, M17 / 189 - 00001

MIL-C-17/75 - Cables, Radio Frequency, Flexible, Coaxial, 50 Ohms, M17/75-RG214, M17 / 190 - 00001

EN 50117-1 Coaxial cables - Part 1: Generic specification

EN 50117-2-4 Coaxial cables Part 2-4: Sectional specification for cables used in cabled distribution networks

EN 50117-9-2 Coaxial cables - Part 9-2: Sectional specification for coaxial cables for analogue and digital signal transmission

EN 50288-4-1 Multi-element metallic cables used in analogue and digital communication and control - Part 4-1: Sectional specification for screened cables characterised up to 600 MHz - Horizontal and building backbone cables

TECHNICAL DATA

GENERAL INFORMATION ABOUT COAXIAL CABLES

Construction And Design

Coaxial cables are mainly built up of four different layers:

1. A centre conductor which is usually a copper wire, which data and video travels through
2. Surrounding the copper wire is a dielectric insulator
3. Screen or outer conductor helps to shield the cable from electromagnetic interference (EMI)
4. The external layer protects the internal layers from physical damages

Inner Conductor

Inner Conductor: The inner conductor shall be solid, stranded, braided or helical, bare or coated like bare copper wire, tin-coated copper wire, silver-coated copper wire, copper-clad steel wire, annealed copper-clad aluminium wire.

Insulation – Dielectric Core: The material used in the dielectric cores specified shall be of uniform thickness consistent with the electrical, environmental, physical, mechanical and dimensional requirements. The dielectric insulation shall be composed of one or more suitable materials. The dielectric may be air spaced, semi-air spaced, foamed or solid. The dielectric shall be continuous and as uniform as possible. Mostly Polyethylene, Solid polyethylene, foamed (Physical) Polyethylene, Polytetrafluoroethylene (PTFE), Fluorinated ethylene propylene (FEP)

Outer Conductor or Screen: Outer conductors or extra shields shall be braided or solid (tubular) like a single or double braid of plain, tinned or silvered annealed copper wire, a copper or aluminium tape formed round the dielectric, a layer of metal or metallized film applied with an overlap, bonded or not bonded, covered with a copper braid (or copper clad wire braid) where the foil is copper and an aluminium or tinned copper braid where the foil is aluminium, a layer of metal or metallized film applied with an overlap, bonded or not bonded covered with two layers

Jacket – Outer Sheath: The jacket material shall be tough, flexible and non-hygroscopic. The jacket shall cover the cable tightly and evenly in a manner consistent with the physical, mechanical, environmental and dimensional requirements. The jacket material shall be PVC, PE, HFFR (LSZH), Polytetrafluoroethylene (PTFE), extruded fluorinated ethylene propylene (FEP) compounds

Coaxial cable, sometimes known as coax cable, is an electrical cable that transmits radio frequency (RF) signals from one point to another.

RG stands for "Radio Guide," is the original military specification for coaxial cables referred as the Mil-C-17 standard. Each type of coaxial cable has a different RG rating to help distinguish the cables' distinct characteristics and specifications.

Part or Identifying RG Number

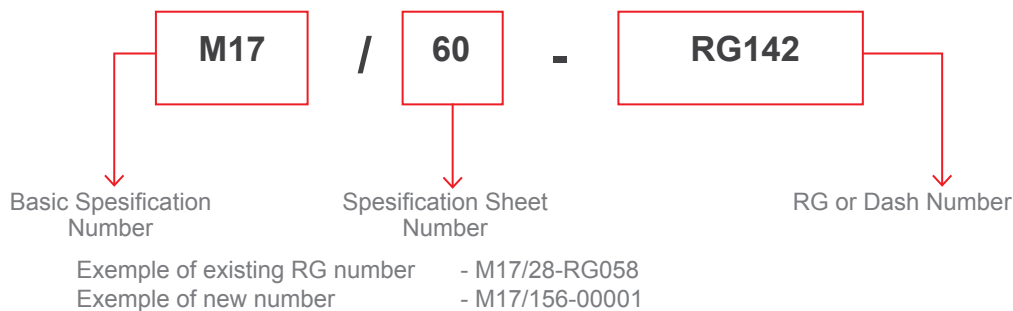

Coln the designation "RG-#/U," the "U" indicates "for general utility use or universal"

They have typically impedances of 50 or 75 Ohms

Coaxial cables like RG6, RG59, RG11 with 75 Ω impedance are used mainly for the multimedia and video application, digital TV and SAT as well as building and studio technology

Coaxial cables like RG58, RG213, RG214 with 50 Ω impedance are used in particular in measurement and test engineering, radio and receiver technology as well as antenna technology.

While each RG cable type offers a variety of capabilities, the most common ones are:

- **RG-59** is a very popular cable in domestic and residential settings. RG-59 has thinner inner conductor that makes the RG-59 the best choice for short distances and low frequency transmissions within the home.
- **RG-6** is for the industry applications and satellite signal transmission, Its bigger conductor provide better signal quality and the bigger dielectric insulation.
- **RG-11** The best coaxial cable for high-definition television is RG11 cable.
A thick, inflexible cable used in outside and underground applications to minimize signal loss in long runs.

TECHNICAL DATA

Mechanical Characteristics of Coaxial Cables

Tensile Strength

To prevent damage to the cable when pulling it through ducts the maximum admissible tensile force stated must not be exceeded. The values stated are based on the assumption that both conductors are firmly attached to each other to carry force. Tensile load can be calculated by following formula.

$$P = \sigma \times s \text{ (Newton)}$$

$$\sigma = 50 \text{ N/mm}^2$$

$$s = \text{sum of conductor cross-sections (mm}^2\text{)}$$

$$P = \text{tensile load in Newton (N)}$$

Bending Properties

The minimum admissible bending radius is stated in the data sheets. After the cable bent to these minimum values, it should not be bent back, because this could result in damage to the cable.

Electrical Characteristic of Coaxial Cables

Characteristic Impedance

The characteristic impedance is based on cable design, cable dimensions, and insulation material. It should be uniform along the cable within broadcasting frequency. Any change of characteristic impedance causes reflections. To obtain maximum power on receiver should be same. Generally the characteristic impedance values of our production line as follows:

50 Ω : Radio communications

75 Ω : CATV, SMATV, CCTV, Video cables

93 Ω - 105 Ω : Local area network and data communications Z_0 characteristic impedance can be calculated from the formulas here below;



$$Z_0 = \frac{60}{\sqrt{\epsilon_r}} \ln \frac{D}{sd}$$

d = conductor diameter (mm)
 D = diameter over insulation (mm)
 S = conductor stranding factor
 ϵ_r = relative dielectric constant
 Z_0 = characteristic impedance (Ω)

Insulation

Insulation	ϵ_r
Solid Polyethylene	2.28
Foamed Polyethylene	1.3.....1.7
Semi Air Spaced Polyethylene	1.3.....1.6

Inductance

At very high frequencies the inductance is approximately

$$L = 2 \cdot 10^{-4} \times \ln \frac{D}{d}$$

d = Conductor diameter (mm)

D = Insulation diameter (mm)

L = Inductance (H/km)

TECHNICAL DATA

Capacitance

The capacitance is the electrical energy accumulated by dielectric materials between conductors. It depends on the dimensions and dielectric material of the cable.

The capacitance of a coaxial cable is:

$$C = \frac{1}{18} \times \frac{\epsilon_r}{\ln \frac{D}{d}}$$

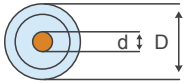

d = conductor diameter (mm)
 D = diameter over insulation (mm)
 ϵ_r = relative dielectric constant
 C = capacitance(pf/m)

Insulation	Capacitance	
	50 Ω	75 Ω
PE	101	67
FPE	85	57

Attenuation

The attenuation of coaxial cables is mainly resistive attenuation which rises with the square root of frequency. Dielectric attenuation is determined by quality and quantity of the insulation material. Its share in total attenuation increases with frequency.

$$\alpha = \alpha_1 \sqrt{f} + \alpha_2 \sqrt{f}$$

$$\alpha_1 \gg \alpha_2$$

$$\alpha = \alpha_1 \sqrt{f}$$

The attenuation of a coaxial cable is defined as follows based on the amplitude of incoming and outgoing signal levels. In addition to these, every °C increases attenuation about 0.2%

$$\alpha = 20 \log_{10} (U_1 / U_2) \text{ dB/m}$$

a : total attenuation
 a1 : resistive attenuation
 a2 : dielectric attenuation
 f : frequency
 U1 : incoming voltage
 U2 : outgoing voltage

The Velocity Of Signal Propagation

Due to skin effect propagation velocity is frequency dependent. Velocity decreases when frequency decreases. In the case of very high frequencies relative propagation velocity of coaxial is dependent the dielectric constant and is as follows.

$$V_r = \frac{c}{\sqrt{\epsilon_r}} \frac{V_r}{c} = \frac{1}{\sqrt{\epsilon_r}}$$

(%of light speed)

V_r = relative propagation velocity (m/sn)

c = light speed (3×10^8)

ϵ_r = relative dielectric constant

TECHNICAL DATA

Return Loss

The irregularities of dimensions, insulation material and installation faults effect the impedance of coaxial cable. Any irregularity or fault causes reflections. The return loss sums the effects of all the impedance variations within the cable and at its ends, at a certain frequency. It is the ration between the vectorial addition of all reflection and the incident signal measured at the near end of the cable. The quantity of reflections is defined by reflection factor.

$$\rho = \frac{V_r}{V_i} \quad A_r = 20 \log \frac{1}{|\rho|}$$

V_i = incident signal

V_r = reflection of signal

ρ = reflection factor in %

A_r = return loss (dB)

Features of Mesh Screening

The non-impair of the signals transmitted by coaxial cables and protection against external influences depends on high screening factor. Most remarkable factors affecting the screening factor are the type, nature and blocking ratio of the folio and/or mesh used for the screen. The blocking factor can be calculated using the following formulae.

$$D_r = D + 2.5 d_w$$

D_r = Diameter with screen

D = Diameter of the isolation

d_w = Diameter of mesh wire

$$\beta = \arctan \frac{\pi \times D_r}{L}$$

β = Mesh angle

L = Mesh step

$$K_f = \frac{m \times n \times d_w}{2 \times L \times \sin \beta}$$

K_f = Coverage coefficient

m = Number of spindles of mesh

n = Number of wires at each spindle

$$K_c = 2K_f - K_{f2}$$

K_c = Blocking ratio

Segment Frequency

At frequencies following the segment frequencies, impairment of nominal distinctive features of coaxial cables are observed.

$$f_c = \frac{1.91 \times V_r}{D + d}$$

$$\lambda = \pi \frac{D + d}{2} \times \frac{1}{10 V_r}$$

f_c = Segment frequency (GHz)

V_r = Relative dissemination speed (%)

D = Insulation diameter (mm)

d = Diameter of inner conductor (mm)

λ_c = Segment wave length (m)

Broadcasting Frequency Bands

	Broadcasting Band	Frequency Invertal
Radio	Long Wave (LW)	148.5 - 283.5 kHz
	Medium Wave (MW)	526.5 - 1606.5 kHz
	Short Wave (SW)	3950 - 26100 kHz
	VHF-Band II (FM)	87.5 - 108 MHz
TV	VHF-BAND I	47 - 68 MHz
	VHF-BAND III	174 - 230 MHz
	UHF-BAND IV/V	470 - 853 MHz
Satallite	SHF-BAND	11.7 - 12.7 GHz



TECHNICAL DATA

INFORMATION ABOUT CATEGORY CABLES

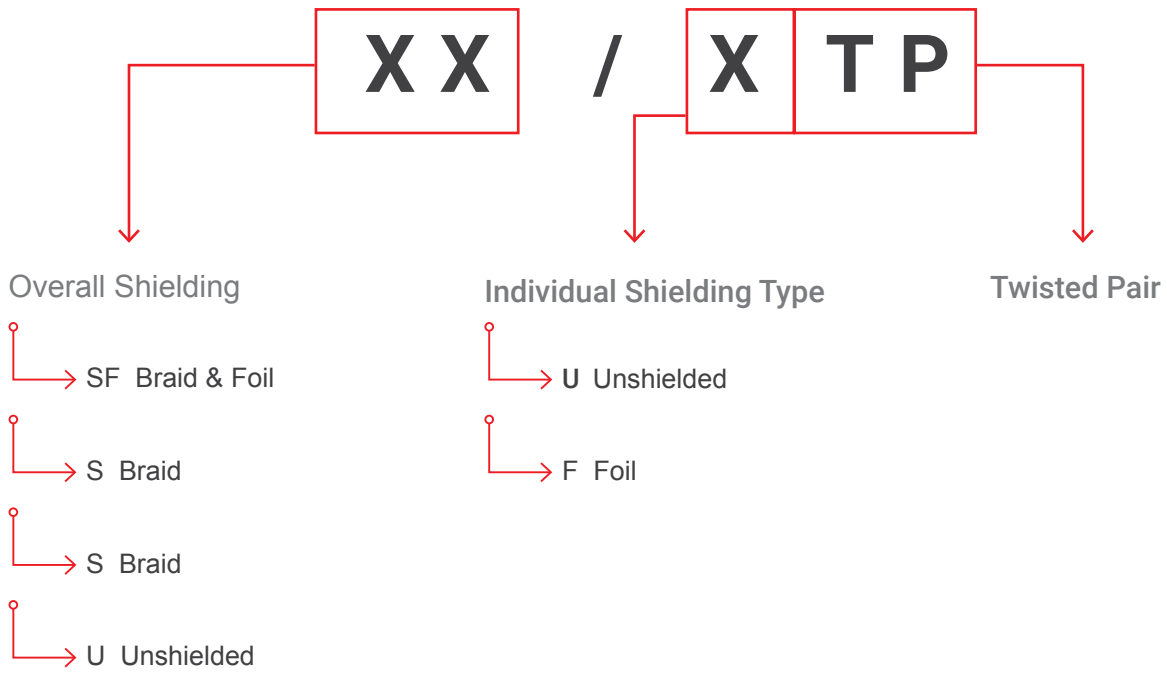

Type of Cable	Product Structure	
U/UTP UTP		
F/UTP FTP		
SF/UTP SFTP		
U/FTP STP		
F/FTP FSTP		
S/FTP SSTP		

TECHNICAL DATA

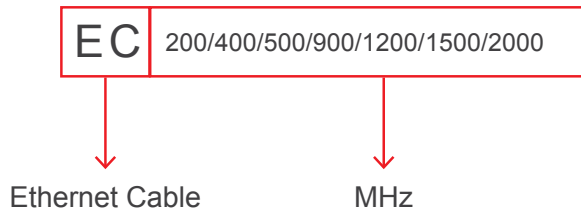

ISO/IEC 11801 / EN50173
 Cat 5e, Cat 6, Cat 6A,
 Cat 7, Cat 7A, Cat 7 A+, Cat 8.2

- EC200 Ethernet Cable 100 MHz ISO/IEC 11801 / EN 50173
- EC400 Ethernet Cable 250 MHz ISO/IEC 11801 / EN 50173
- EC500 Ethernet Cable 500 MHz ISO/IEC 11801 / EN 50173
- EC900 Ethernet Cable 600 MHz ISO/IEC 11801 / EN 50173
- EC1200 Ethernet Cable 1000 MHz ISO/IEC 11801 / EN 50173
- EC1500 Ethernet Cable 1200 MHz ISO/IEC 11801 / EN 50173
- EC2000 Ethernet Cable 1500 MHz ISO/IEC 11801 / EN 50173

Cable Standard and Frequency Values

Classification	Max. Frequency MHz	Descriptions
Cat 3	16	Terminated in T568-B standard. It can provide a frequency transition of 16 MHz. Can send 10 Mbit of data in one second. Today, Cat 1 is in place and IP is used as a phone line in non telephone IP available lines.
Cat 4	20	It is suitable for a frequency transition of 20 MHz. 16 Mbit of data is transmitted in seconds.
Cat 5e	100	It can be used up to 100 m. There are two types, stranded and hard wired. The stranded cable is preferred for patch cable construction. Because its structure is soft, it is not suitable for long length use.
Cat 6	250	It is suitable for a frequency pass of 250 MHz. Today Cat5e takes its place. It has a transport capacity of 1 Gbit/s.
Cat 6e	-	Cat 6e is not a category approved by TIA. The value declared by the manufacturer is important. The operating frequency range is between 250 and 500 MHz.
Cat 6A (500)	500	It is suitable for a data transfer of 500 MHz. It is preferred for data transmission of 1 Gigabit and higher. Cable cross section is thicker than Cat 5 and Cat 6.
Cat 7	600	In fact, this cable, which is produced as STP, has started to be produced as U/FTP and F/FTP according to technological development and needs. But the areas of use are very low. It is suitable for 600 MHz data transfer. It is preferred in 10 Gigabit data transmission.
Cat 7A (1 GHz)	1000	It is suitable for 1000 MHz data transfer. It is preferred for 40 Gigabit data transmission .
Cat 7A +	1200	It is suitable for 1200 MHz data transfer. It is preferred for 40 Gigabit data transmission.
Cat 8.2	2000	It is suitable for 2000 MHz data transfer. The application areas and the standard are in development stage.

TECHNICAL DATA

TESTS ON ELECTRIC CABLES UNDER FIRE CONDITIONS

IEC 60332/3 Fire test on bunched and vertical laid cables.
Test chamber

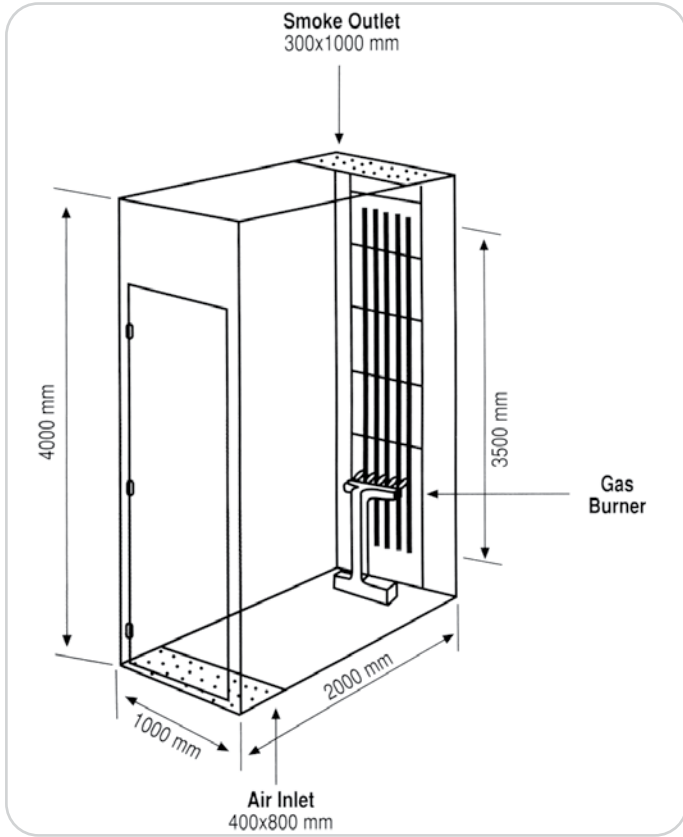

Flame application time

Required volume of combustible material
per 1 m of cable bunch (lt) : V

IEC 60332/3 CATEGORY	V	MINIMUM BURNING TIME
A	7lt.	40 minutes
B	3.5lt.	40 minutes
C	1.5lt	20 minutes

Test Conditions of IEC 60332/3

This test is to determine the fire propagation characteristics of a bunch of cables. The test should be carried out if the external wind speed measured by an anemometer fitted on the top of the test rig is not greater than 5 m/s and the temperature of the walls of the test chamber is in between 5 °C and 40 °C. The temperature inside of the chamber should be 23±5 °C before the test

IEC 60331 - 21 Fire Test for circuit integrity

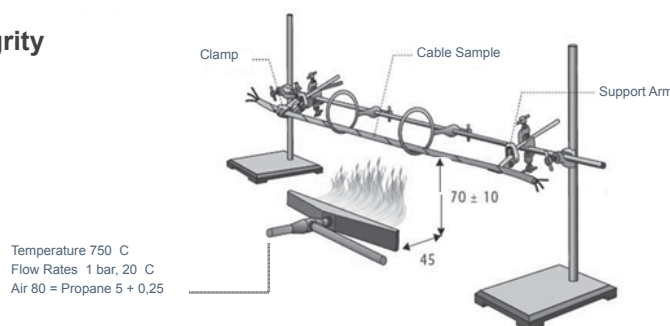

IEC 60332/1 Fire test on a vertical laid single cable. Test chamber

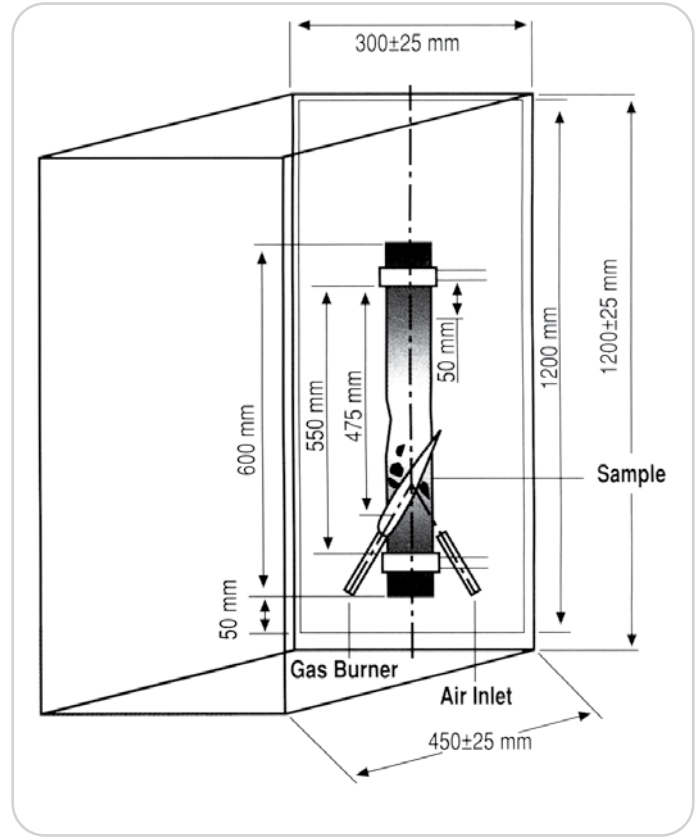

Flame application time

Weight of test piece (kg) : m
Flame application time (s) = 60+m/25

TECHNICAL DATA

Smoke Intensity

IEC 61034-2 / EN 61034-2 / DIN VDE 0482-1034-2

Cable bundle to be tested will be placed inside a metal tray containing $\pm 1\%$ alcohol mixture per 1 liter and will be ignited inside a cabinet with a size of 3 m³.

100W standard halogen and photocell based lamp and photometric system is positioned inside a cube with a height of 215 cm (± 10 cm), in the horizontal position on a medium vertical axis. Light transmission of the generated smoke is measured optically.

- Test equipment and flame verification must be in compliance with IEC/EN 61034-1 Standard.

Overall Diameter mm	Sample Number	Light Transmission
D > 40	1	> 60 %
20 < D ≤ 40	2	> 60 %
10 < D ≤ 20	3	> 60 %
5 < D ≤ 10	N ₁	> 60 %
1 < D ≤ 5	N ₂	> 60 %

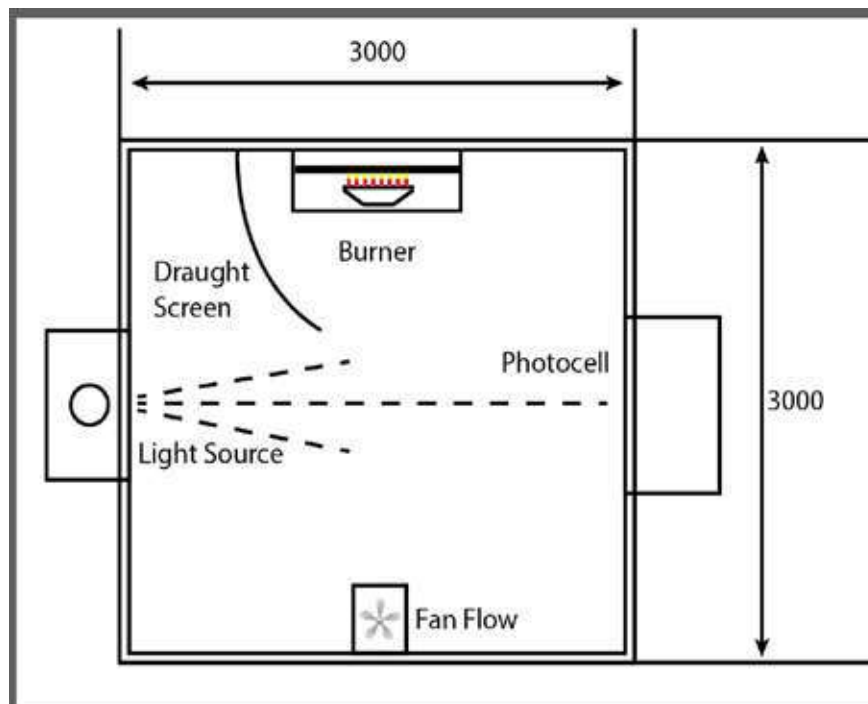

Compliance Requirement

In order for the cable to pass the test, light absorption assessed in photometric terms should be seen within 40 minutes. Also minimum 60% light transmission should be obtained. In such a case, the cable passes the test.

TECHNICAL DATA

pH Measurement and Conductivity Test

IEC 60754-2 / EN 60754-2

Cable to be subjected to this test which allows measuring corrosive gas emission of insulation or outer sheath composition must be 1 gram. Cable's insulation or outer sheath composition is heated at a temperature of 935°C. Gases formed as the result of test that lasts for 30 minutes are dissolved in distilled water with pH and conductivity. Halogen is calculated accordingly.

- Test equipment and flame verification must be in compliance with EN 50267-1 Standard.

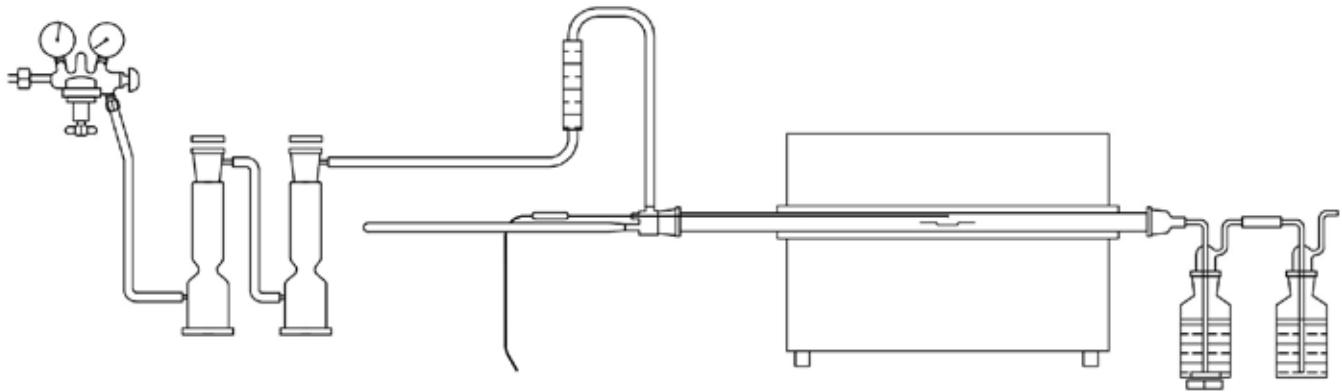

Test apparatus - method 2

Compliance Requirement

In order for the cable to pass the test, pH value measured should be 4.3 or higher. Also it is expected for the electrical conductivity to be 10 μ S/mm or less.

TECHNICAL DATA

Cables and Drums User Guide Drums Handling

1.1.Position of Drums

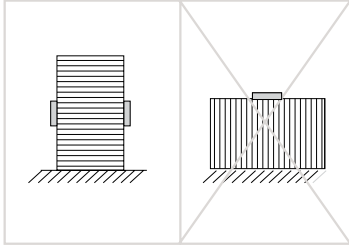

1.2.Loading

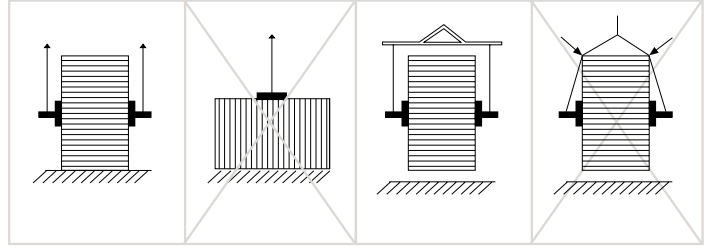

1.3.Unloading

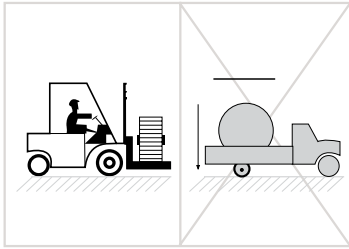

1.4.Handling by forklift

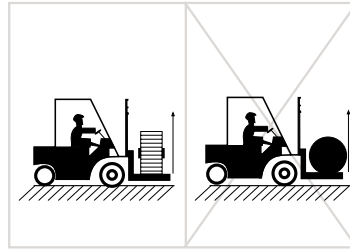

1.5.Rolling

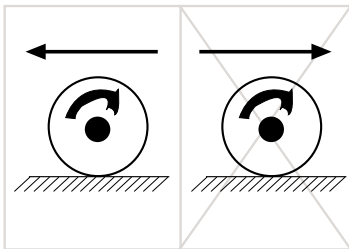

1.6.Paying-off the Cable

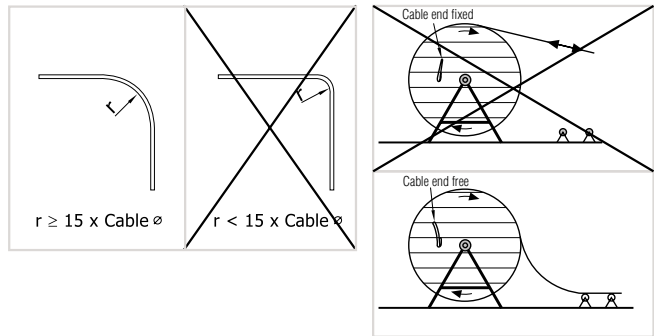

Transport Requirements

2.1.Position of the Drums

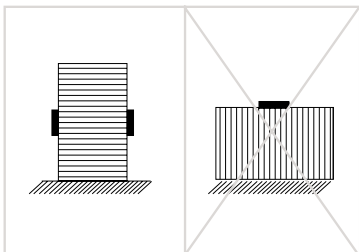

2.2.Fastening Drums

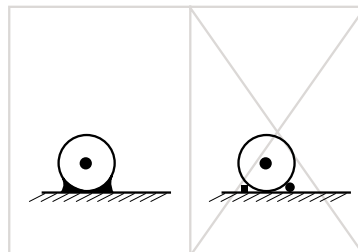

Cables and Drums User Guide

2.3.Use of nails

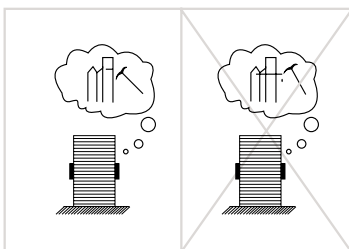

2.4.Bigger Drums

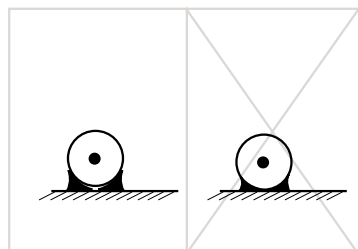

TECHNICAL DATA

2.5. Binding of the Drums

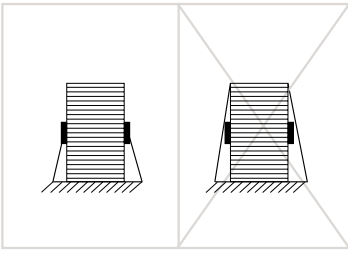

2.6. Multiple Drum Storage

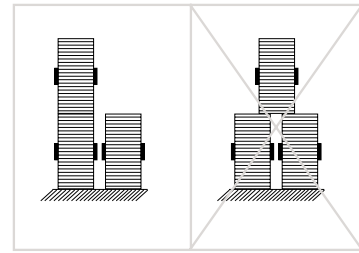

Storage Requirements

3.1. Do not store near heat sources

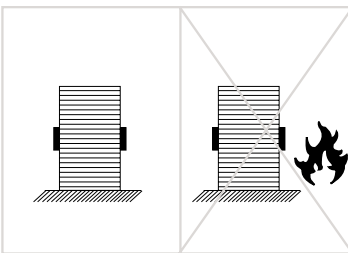

3.2. Do not store on vibrating surfaces. (Ship engine room etc.)

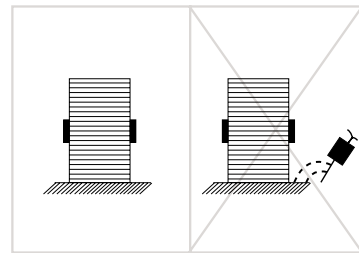

3.3. Do not store on irregular surfaces.

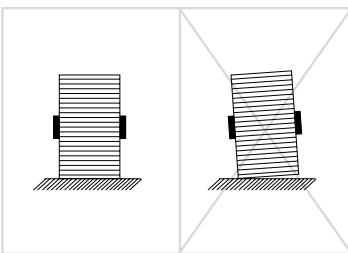

3.4. Do not store on soft surfaces

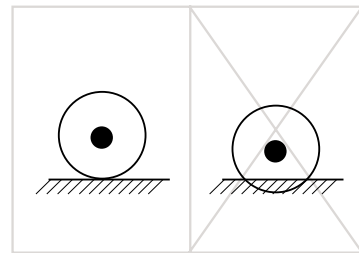

Cables and Drums User Guide

3.5. Do not store on areas liable of flooding. All cable ends must be fully sealed at all times to prevent the ingress of water. It is preferable to store reels off the ground on timbers or other supports. In damp locations, it is advisable to allow at least 3 inches between reels to permit circulation of air.

3.6. If storage is likely to last more than 6 months, drums should be stored in order to be protected from effects like rain, sunlight etc.

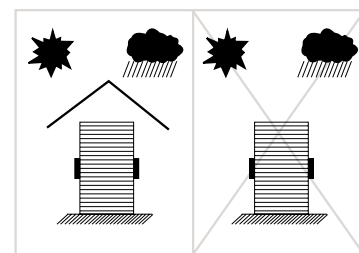
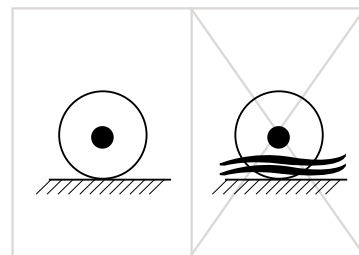

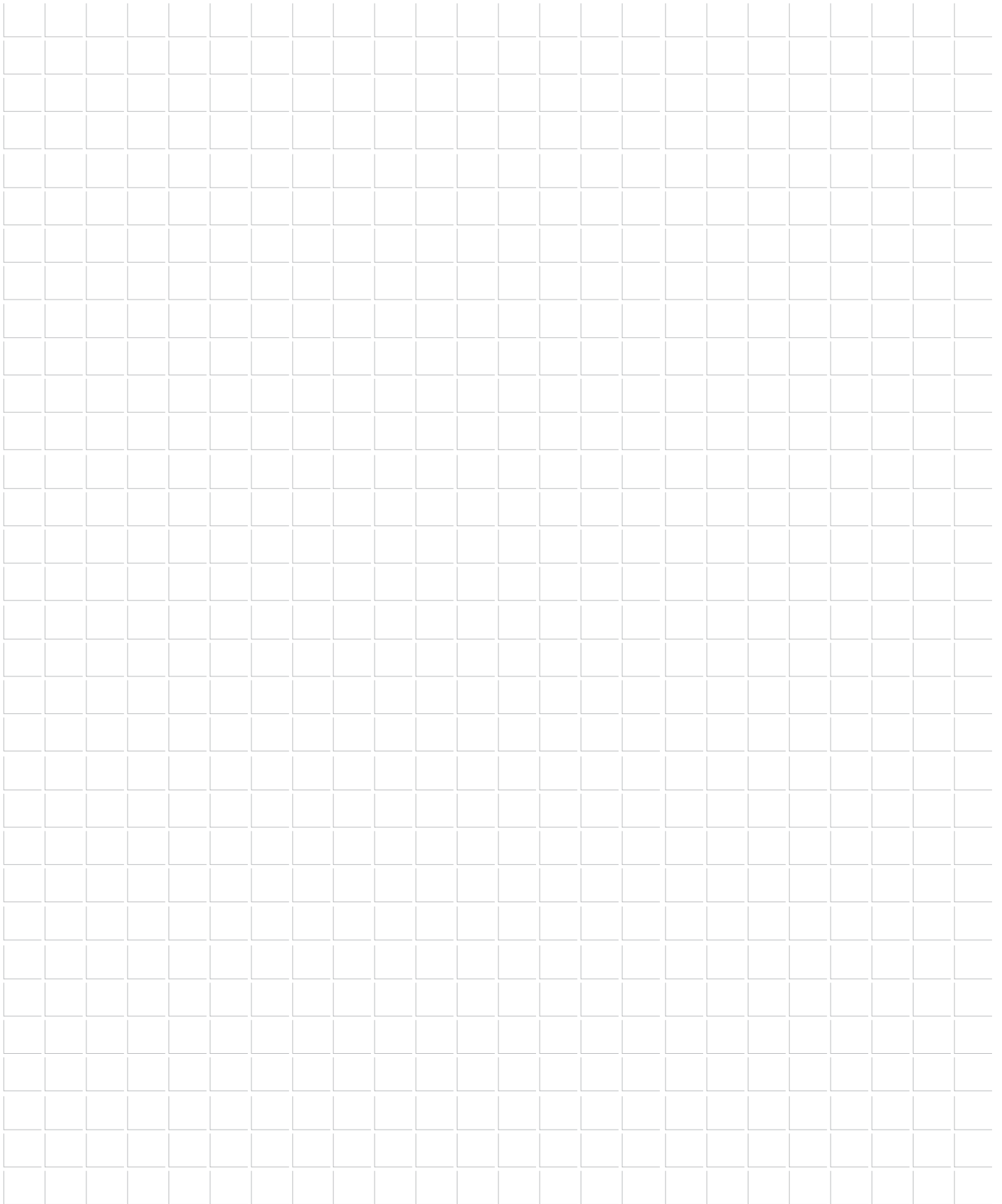

**OFFSHORE
CABLES**



**AIRPORT
CABLES**



**CRANE
CABLES**



**MINING
CABLES**



**DEFENSE
INDUSTRY
CABLES**



**MARINE
CABLES**



**RAILWAY
CABLES**



**INDUSTRIAL
CABLES**



**TUNNELLING
CABLES**



**INSTRUMENTATION
CABLES**



Üntel Kabloları San. ve Tic. A.Ş.

Makine O.S.B. 6. Cadde No:4/41455 Dilovası, Kocaeli - TÜRKİYE

Tel: +90 262 722 93 30 Fax: +90 262 722 94 43

info@untel.com.tr | www.untel.com.tr